

AS1050R

INSTRUCTION FOR USE

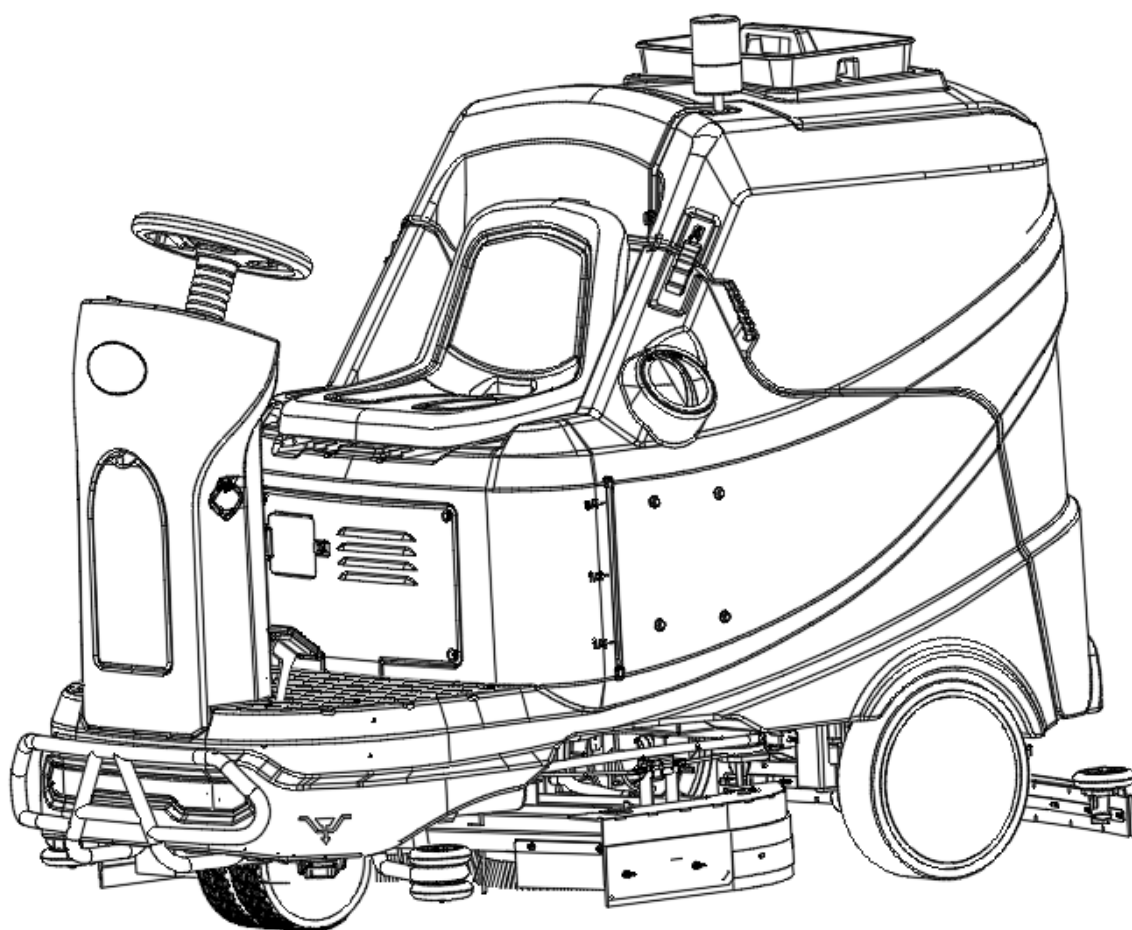

Model No.: 50000594

VR41009 Rev. 03 JUNE 2021

Original instructions



VIPER



EU / UE / EL / EC / EE / ES / EÚ / AB

Declaration of Conformity

Prohlášení o shodě
Konformitätserklärung
Overensstemmelseserklæring
Declaración de conformidad
Vastavusdeklaratsioon
Déclaration de conformité
Vaatimustenmukaisuusvakuutus

Декларация за съответствие
Δήλωση συμμόρφωσης
Megfelelősségi nyilatkozat
Izjava o skladnosti
Dichiarazione di conformità
Atitikties deklaracija
Atbilstības deklarācija
Samsvarserklæring
Conformiteitsverklaring

Declaração de conformidade
Deklaracija zgodności
Declaratie de conformitate
Декларация о соответствии
Försäkran om
överensstämmelse
Vyhlášení o zhode
Izjava o skladnosti
Uygunluk beyanı

Manufacturer / Výrobce / Hersteller / Fabrikant /
Fabricante / Κατασκευαστής / Gyártó / Proizvođač /
Fabbicante / Gamintojas / Ražotājs / Producent / Fabrikant
/ Fabricante / Producent / Producător / производитель /
Tillverkaren / Výrobca / Proizvajalec / Üretici firma:

**Nilfisk A/S, Kornmarksvej 1
DK-2605 Broendby, DENMARK**

Product / Produkt / Producto, Toode, Produit, Tuote/
Продукт / Προϊόν / Termék / Proizvod / Prodotto /
Produktas / Produkts / Artikel / Produtos / Produis / Izdelek
/ Ürün

AS1050R, AS1050R+

Description / Popis / Beschreibung / Beskrivelse /
Descripción / Kirjeldus / La description / Kuvaus / Описание
/ Περιγραφή / Leirás / Opis / Descrizione / Aprašymas /
Apraksts / Beschrijving / Descrição / Descriere / Beskrivning
/ Popis / Açıklama

**FC - Floor Scrubber/Sweeper - Battery
36V DC, IP24**



We, Nilfisk hereby declare under our sole responsibility, that the above-mentioned product(s) is/are in conformity with the following directives and standards.



Mes, „ Nilfisk“, prisiimdami visišką atsakomybę pareiškiame, kad pirmiau minėtas produktas (-ai) atitinka šias direktyvas ir standartus



My, Nilfisk prohlašujeme na svou výlučnou odpovědnost, že výše uvedený výrobek je ve shodě s následujícími směrnici a normami.



Mēs, Nilfisk, ar pilnu atbildību apliecinām, ka iepriekšminētais produkts atbilst šādām direktīvām un standartiem



Wir, Nilfisk erklären in alleiniger Verantwortung, dass das oben genannte Produkt den folgenden Richtlinien und Normen entspricht.



Vi, Nilfisk erklærer herved under eget ansvar, at det ovennevnte produktet er i samsvar med følgende direktiver og standarder



Vi, Nilfisk erklærer hermed under eget ansvar at ovennævnte produkt(er) er i overensstemmelse med følgende direktiver og standarder.



We verklaren Nilfisk hierbij op eigen verantwoordelijkheid, dat het bovengenoemde product voldoet aan de volgende richtlijnen en normen



Nosotros, Nilfisk declaramos bajo nuestra única responsabilidad que el producto antes mencionado está en conformidad con las siguientes directivas y normas



Nós, a Nilfisk declaramos, sob nossa exclusiva responsabilidade, que o produto acima mencionado está em conformidade com as diretrizes e normas a seguir

ET

Meie, Nilfisk Käesolevaga kinnitame ja kanname ainuisikulist vastutust, et eespool nimetatud toode on kooskõlas järgmiste direktiivide ja

FR

Nilfisk déclare sous notre seule responsabilité que le produit mentionné ci-dessus est conforme aux directives et normes suivantes.

FI

Me, Nilfisk täten vakuutamme omalla vastuulla, että edellä mainittu tuote on yhdenmukainen seuraavien direktiivien ja standardien mukaisesti

BG

Ние, Nilfisk С настоящото декларираме на своя лична отговорност, че посочените по-горе продуктът е в съответствие със следните директиви и стандарти.

EL

Εμείς, Nilfisk δηλώνουμε με αποκλειστική μας ευθύνη, ότι το προαναφερόμενο προϊόν συμμορφώνεται με τις ακόλουθες οδηγίες και πρότυπα.

HU

Mi, Nilfisk Kijelentjük, egyedüli felelősséggel, hogy a fent említett termék megfelel az alábbi irányelveknek és szabványoknak

HR

Mi, Nilfisk Izjavljujemo pod punom odgovornošću, da gore navedeni proizvod u skladu sa sljedećim direktivama i standardima.

IT

Noi, Nilfisk dichiara sotto la propria responsabilità, che il prodotto di cui sopra è conforme alle seguenti direttive e norme.

PL

My, Nilfisk Niniejszym oświadczamy z pełną odpowiedzialnością, że wyżej wymieniony produkt jest zgodny z następującymi dyrektywami i normami..

RO

Noi, Nilfisk Prin prezenta declarăm pe propria răspundere, că produsul mai sus menționat este în conformitate cu următoarele standarde și directive

RU

Ми, Нилфиск овим изјављујем под пуном одговорношћу, да наведеног производ је у складу са следећим директивама и стандардима

SV

Vi Nilfisk förklarar härmed under eget ansvar att ovan nämnda produkt överensstämmer med följande direktiv och normer.

SK

My, Nilfisk prehlasujeme na svoju výlučnú zodpovednosť, že vyššie uvedený výrobok je v zhode s nasledujúcimi smernicami a normami.

SL

Mi, Nilfisk izjavljamo s polno odgovornostjo, da je zgoraj omenjeni izdelek v skladu z naslednjimi smernicami in standardi.

TR

Nilfisk, burada yer alan tüm sorumluluklarımıza göre, yukarıda belirtilen ürünün aşağıdaki direktifler ve standartlara uygun olduğunu beyan ederiz.

2006/42/EC

EN 60335-1:2012+A11:2014+A13:2017
EN 60335-2-72:2012

2014/30/EU

EN 55014-1:2017
EN 61000-6-2:2019

Authorized
signatory:

Pierre Mikaelsson, Executive Vice President, Global Products & Services,
Nilfisk NLT

Oct 27, 2020





UK Declaration of Conformity

We,
Nilfisk Ltd
Nilfisk House, Bowerbank Way Gilwilly Industrial Estate
Penrith Cumbria
CA11 9BQ UK

Hereby declare under our sole responsibility that the

Product: FC - Floor Scrubber/Sweeper - Battery
Description: 36V DC, IP24
Type: AS1050R, AS1050R+

Is in compliance with the following standards:

EN 60335-1:2012+A11:2014+A13:2017
EN 60335-2-72:2012
EN 55014-1:2017
EN 61000-6-2:2019

Following the provisions of:

Supply of Machinery (Safety) Regulations 2008/1597
Electromagnetic Compatibility Regulations 2016/1091

Penrith, 8-4-2021

A handwritten signature in black ink, appearing to be "Stewart Dennett". The signature is written in a cursive style with a long, sweeping underline.

Stewart Dennett
GM/MD

TABLE OF CONTENTS

INTRODUCTION.....	2
GUIDE PURPOSE AND CONTENTS	3
HOW TO KEEP THIS INSTRUCTION FOR USE.....	3
DECLARATION OF CONFORMITY	3
ACCESSORIES AND MAINTENANCE.....	3
CHANGE AND IMPROVEMENT.....	3
SCOPE OF APPLICATION.....	3
MACHINE IDENTIFICATION DATA.....	3
TRANSPORT AND UNPACKING.....	4
SAFETY	4
VISIBLE SYMBOLS ON THE MACHINE	4
SYMBOLS THAT APPEAR ON THE INSTRUCTION FOR USE	4
GENERAL SAFETY INSTRUCTION	5
MACHINE DESCRIPTION	7
MACHINE STRUCTURE *--optional.....	7
CONTROL PANEL (as shown)	8
TECHNICAL PARAMETERS	11
WIRING DIAGRAM	12
OPERATING GUIDE	13
BATTERY CHECK/SETTING ON A NEW MACHINE	13
BATTERY INSTALLATION AND BATTERY TYPE SETTING (WET OR GEL/ AGM)	13
BRUSH/PAD-HOLDER INSTALLATION AND REMOVAL	14
ADJUSTING THE BALANCE OF SIDE SPLASHGUARDS.....	15
ADJUSTING THE BALANCE OF SQUEEGEE	15
FILLING SOLUTION TANK.....	16
DRIVE MOTOR AND MECHANICAL BRAKE INSPECTION	16
MACHINE START AND STOP.....	16
MACHINE OPERATION (SCRUBBING AND DRYING)	17
TANK EMPTYING	18
AFTER USING THE MACHINE	18
MACHINE STORAGE DURING LONG INACTIVITY.....	18
FIRST PERIOD OF USE	19
MAINTENANCE.....	19
SCHEDULED MAINTENANCE TABLE	19
BATTERY CHARGING.....	20
BRUSH/PAD CLEANING	20
SOLUTION FILTER CLEANING	21
SQUEEGEE CLEANING	21
SQUEEGEE BLADE CHECK AND REPLACEMENT	21
TANK AND DEBRIS COLLECTION BOX CLEANING, AND COVER GASKET CHECK	22
ACCESSORIES/OPTIONS.....	22
TROUBLESHOOTING	22
ERROR CODE OF DISPLAY	23
SCRAPPING	24

INTRODUCTION



NOTE

The numbers in brackets refer to the components shown in Machine Description chapter.

GUIDE PURPOSE AND CONTENTS

The purpose of this instruction for use is to provide the operator with all basic information and technical characteristics, operation, machine inactivity, spare parts and safety conditions etc.

Before performing any procedure on the machine, the operators and qualified technicians must read the Instruction for Use manual. Contact our company in case of doubts concerning the interpretation of the instructions or for any further information.

HOW TO KEEP THIS INSTRUCTION FOR USE

The instruction for use must be kept near the machine, inside an adequate case, away from liquids and other substances that can cause any damage to it.

DECLARATION OF CONFORMITY

Declaration of Conformity is supplied with the machine and certifies machine conformity with the law in force.



NOTE

The copies of the original declaration of conformity are provided together with the machine documentation.

ACCESSORIES AND MAINTENANCE

All the necessary operation, maintenance and repair procedures must be made by qualified personnel, our company appointed repair center. ONLY original or approved spare parts and accessories can be used.

Contact our company customer service for any service or purchase of accessories or spare parts if necessary.

CHANGE AND IMPROVEMENT

We are committed to continuous improvement of our products, and the company reserves the right to machine changes and improvements without additional information.

SCOPE OF APPLICATION

The scrubber applies to commercial and industrial use. It is suitable for cleaning smooth and solid floor, operating by a qualified person in safe circumstances. It is not suitable for outdoor use or on carpet or rough floor cleaning.

MACHINE IDENTIFICATION DATA

The machine serial number and model name are marked on the serial label.

This information is useful. Use the following table to write down the machine identification data when requiring spare parts for the machine.

MACHINE MODEL.....
MACHINE SERIAL NUMBER.....

TRANSPORT AND UNPACKING

When the carrier delivers the machine, make sure the packaging and machine are both whole and undamaged. If any damage is observed, inform the carrier of the damage before accepting the goods, to reserve the right to compensation for the damage.

Follow the instructions on packaging strictly when unpacking the machine.

Check the package to ensure following items are included:

1. Technical documentation - Instruction for use.
2. Battery connection components.
3. Electronic battery charger manual (if installed) (*)

SAFETY

The following symbols indicate potentially dangerous situations. Always read this information carefully and take all necessary precautions to safeguard people and property.

VISIBLE SYMBOLS ON THE MACHINE



WARNING!

Read all the instructions carefully before performing any operation on the machine.



WARNING!

Do not wash the machine with direct or pressurized water jets.



WARNING!

Do not use the machine to work on slopes with a gradient exceeding that is defined in the specifications section.

SYMBOLS THAT APPEAR ON THE INSTRUCTION FOR USE



DANGER!

It indicates a dangerous situation with risk of death for the operator.



WARNING!

It indicates a potential risk of injury for people.



CAUTION!

It indicates a caution, or a remark related to important or useful functions. Pay attention to the paragraphs marked by this symbol.



NOTE

It indicates a remark related to important or useful functions.



CONSULTATION

It indicates the necessity to refer to the Instruction for Use manual before performing any procedure.

GENERAL SAFETY INSTRUCTION

Specific warnings and cautions to inform about potential damages to people and machine are shown below.

**DANGER!**

- This machine must be operated by trained and authorized personnel according to guidance of the manual.
- Before performing any cleaning, maintenance, repair or replacement procedure, read all the instructions carefully, ensure to turn the machine OFF and disconnect the battery connector.
- Do not operate the machine near toxic, dangerous, flammable and/or explosive powders, liquids or vapor. This machine is not suitable for collecting dangerous powders.
- Do not wear jewelry when working near electrical components.
- Do not work under the lifted machine without supporting it with safety stands.
- When using lead (WET) batteries, they may emit inflammable gas under normal use, you must keep sparks, flames, smoking materials and radiating, illuminating and burning items away from the batteries.
- When charging lead (WET) batteries, they may emit hydrogen gas which may cause explosive. You must ensure the charging environment is well ventilated and away from flames.

**WARNING!**

- This machine is intended for **COMMERCIAL USE**, for example in hotels, schools, hospitals, factories, shops, offices and rental businesses.
- Machines left unattended shall be secured against unintentional movement.
- In order to prevent unauthorized use of the machine, the power source shall be switched off or locked, for example by removing the key of the main switch or the ignition key.
- Check the machine carefully before each use. Ensure that all the components have been well assembled before use. Loose components may cause damage to people and properties.
- Never move the machine by pulling the battery charger cable. Do not pass the cable through a closed door or wind the cable around sharp edges or corners. Do not run the machine over the battery charger cable. Keep the battery charger cable away from heated surfaces.
- Do not charge the batteries if the battery charger cable or the plug are damaged.
- To reduce the risk of fire, electric shock, or injury, make sure machine is off before leaving.
- Use or store the machine indoors in dry conditions, it is not allowed for outdoor use.
- The machine storage and working temperature must be between 0 °C and +40 °C, the humidity of air must be between 30% - 95%.
- Do not use the machine on slopes with a gradient exceeding the specifications shown.
- When using and handling floor cleaning detergents, follow the instructions on the labels of the detergent bottles and wear suitable gloves and other protective devices.
- Use brushes and pads supplied with the machine or defined in the manual. Using other brushes or pads could reduce safety.
- In case of machine malfunctions, ensure that these are not due to lack of maintenance. If necessary, request assistance from the authorized personnel or from an authorized Service Center.
- Take all necessary precautions to prevent hair, jewelry, and loose clothes from being caught by the machine moving parts.
- Do not use the machine in particularly dusty areas.
- Do not wash the machine with direct or pressured water jets, or with corrosive substances.

- **Do not bump into shelves or scaffoldings, especially where there is a risk of falling objects.**
- **Do not lean liquid containers on the machine, use the relevant can holder.**
- **To avoid damaging the floor, do not allow the brush/pad to operate while the machine is stationary.**
- **In case of fire, use a dry powder fire extinguisher. Do not use liquid fire extinguishers.**
- **Do not remove or modify the machine labels.**
- **Do not tamper with the machine safety guards and follow the scheduled maintenance instructions closely.**
- **Pay attention during machine transportation when temperature is below freezing point. The water in the recovery tank and in the hoses could freeze and cause serious damage to the machine.**
- **If spare parts need be replaced, order ORIGINAL spare parts from an Authorized Dealers or Retailers.**
- **Return the machine to the Service Center if it doesn't work as usual or it is damaged.**
- **To ensure machine proper and safe operation, the scheduled maintenance shown in the relevant chapter of this Manual, must be performed by the authorized personnel or an authorized Dealers or Retailers.**
- **The machine must be properly disposed of, due to the presence of toxic-harmful materials (batteries, etc.), which are subject to standards that require disposal in special centers (see Scrapping chapter).**
- **This machine is a cleaning tool only and is not intended for any other purpose.**
- **Always keep the openings free from dust, hairs and any other foreign material which could reduce the air flow. Do not use the machine if the openings are clogged.**
- **Use the machine only where proper lighting is provided.**
- **This machine is not intended for use by persons (including children) with reduced physical, sensory or mental capabilities, or lack of experience and knowledge.**
- **Close attention is necessary when used near children.**
- **Children should be supervised to ensure that they do not play with the machine.**
- **While using this machine, take care not to cause damage to people or objects.**
- **Cleaning and user maintenance shall not be made by children without supervision.**
- **Operators shall be adequately instructed on the use of these machines.**
- **Do not use the machine without a falling object protective structure (FOPS) in areas where it is likely that the operator is hit by falling objects.**

MACHINE DESCRIPTION

MACHINE STRUCTURE *--optional

1. Steering wheel
2. Seat, adjustable (with safety switch)
3. Warning light
4. Utility caddy (*)
5. Recovery tank lid
6. Hook
7. Latch(x2)
8. Recovery tank
9. Filter cover
10. Filter hose holder
11. Filter support
12. Solution tank
13. Water level tube
14. Drive wheels (with mechanical brake)
15. Side splashguards
16. Brush assembly
17. Pump
18. Bumper wheels
19. Solution tank drain cover
20. Front wheels
21. Front lights
22. Solution filter
23. Front bumper
24. Solution shut-off valve
25. Mechanical brake pedal
26. Internal storage cover
27. USB charging port

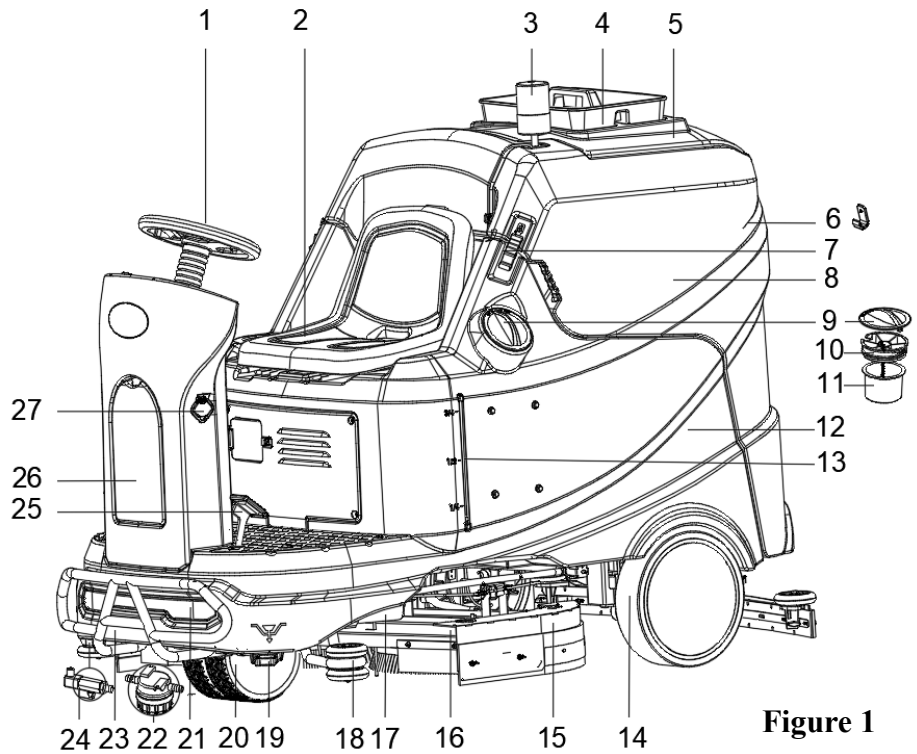

Figure 1

28. Control panel
29. Emergency switch
30. Cup holder
31. Recovery tank support cable
32. Accelerator pedal
33. Brush/Pad driver installation stop
34. Squeegee knobs
35. Squeegee angle adjusting knob
36. Squeegee vacuum hose
37. Squeegee
38. Recovery water drain hose
39. Squeegee hook
40. Debris collection box
41. Vacuum intake filter
42. Tank cover gasket
43. Batteries (N/A)
44. Battery tray (*)
45. Vacuum system
46. Dual vacuum system (*)

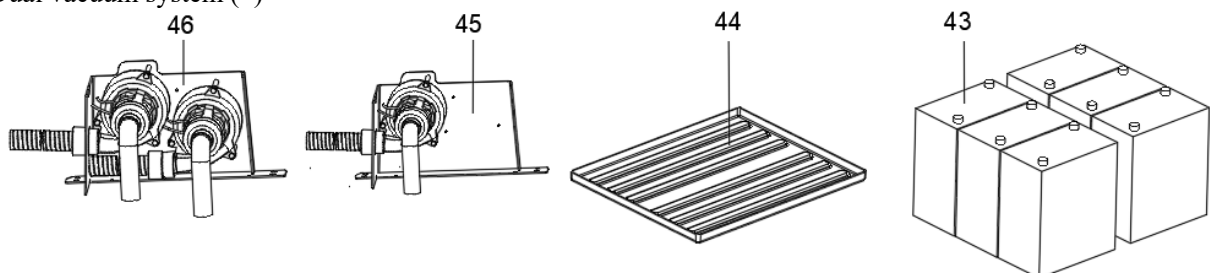
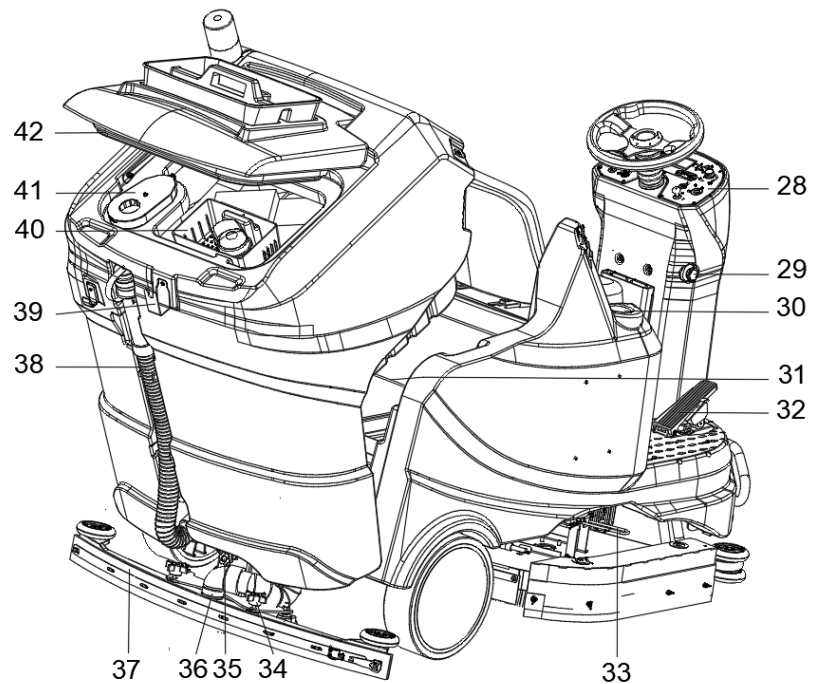

Figure 2

CONTROL PANEL (as shown)

- 47. Multifunction display
 - Items displayed:
 - A) Battery type
 - B) Battery charge level
 - C) Hours worked
 - D) ECO mode
 - E) Vacuum normal mode
 - F) Vacuum silence mode
 - G) Reverse mode
 - H) Extra pressure active
 - I) Detergent solution flow quantity
 - J) Brush work mode
 - K) Vacuum mode
 - L) Seat safety switch off
- 48. Recovery tank full/ solution Tank empty indic
- 49. Speed adjust knob
- 50. Solution flow adjusting buttons
- 51. One-button start
 - LED on above button-function activated
 - water system (level 2)
 - pressure at minimum (level 1)
 - vacuum system normal
- 52. Forward-reverse button
- 53. Ignition key (0=ON I=OFF)
- 54. Vacuum system adjustment button (press the button 1 second to activate)
 - LED Steady on -normal mode
 - LED Flashing -Silent mode
- 55. ECO mode button
 - LED on above button-function activated
 - water flow at minimum (level 1)
 - pressure at minimum (level 1)
 - Vacuum in silent mode
- 56. Brush/pad-holder click on/off
 - LED Flashing-Click on activated
- 57. Brush pressure adjusting buttons
- 58. Horn button
- 59. Front light button
- 60. Charger plug cover
- 61. Brush motors overload protectors (30A)
- 62. Brush lift overload protector (3A)
- 63. Charger plug
- 64. Main control circuit overload protector (5A)
- 65. Vacuum motor(s) overload protector (30A)
- 66. Squeegee lift overload protector (3A)

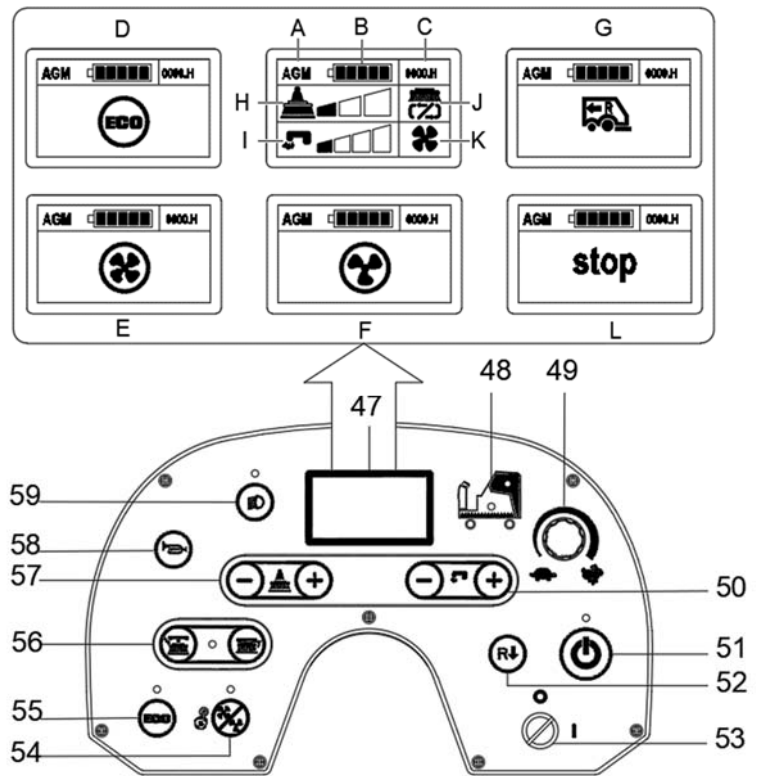

Figure 3

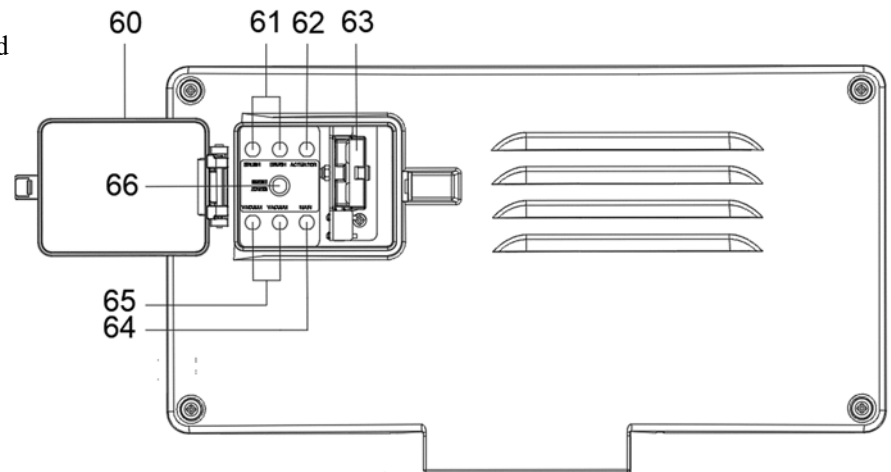
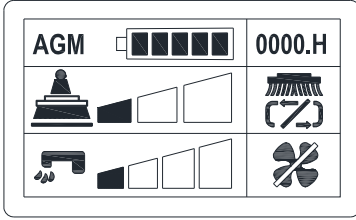
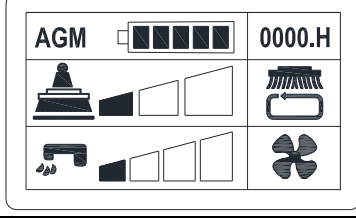
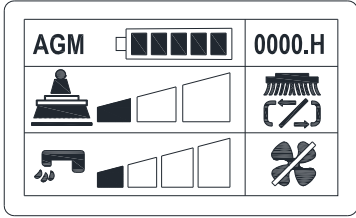
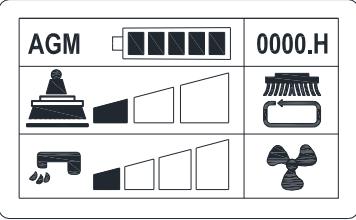
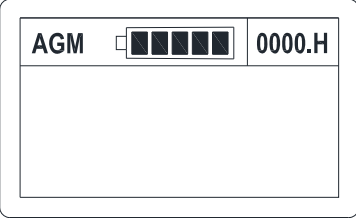
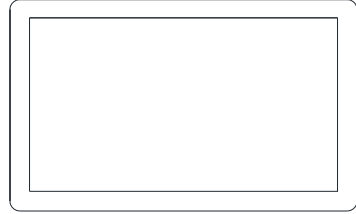
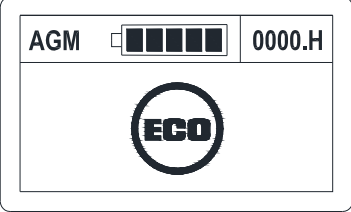
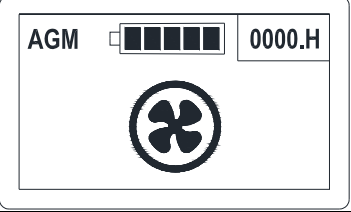
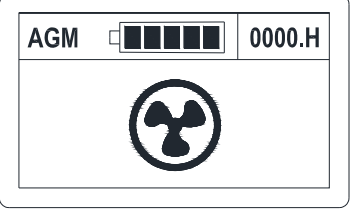
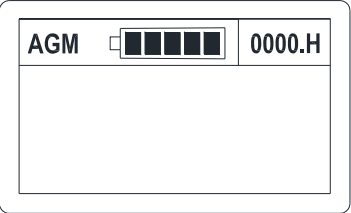
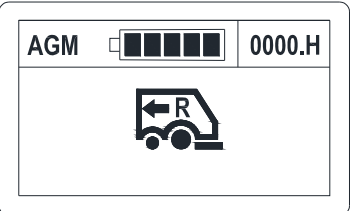
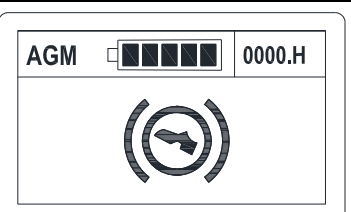

Figure 4

WORKING MODE DESCRIPTION

HOW TO OPERATE	DISPLAY	DESCRIPTION
Normal mode		
<ul style="list-style-type: none"> - Key (53) on - One button start (51) on - Seat safety switch (2) on 		<ol style="list-style-type: none"> 1. Hour meter point does not flash. 2. The brush arrow does not rotate. 3. The fan does not flash. 4. The tap water does not flash. 5. The actuator puts down to the first level brush pressure.
<ul style="list-style-type: none"> - Key (53) on - One button start (51) on - Seat safety switch (2) on - Accelerator pedal (32) pressed 		<ol style="list-style-type: none"> 1. Hour meter point flashes. 2. The brush arrow rotates. 3. The fan flashes. (Four blades) 4. The tap water flashes.
Silent mode		
<ul style="list-style-type: none"> - Key (53) on - One button start (51) on - Seat safety switch (2) on 		<ol style="list-style-type: none"> 1. Hour meter point does not flash. 2. The brush arrow does not rotate. 3. The fan does not flash. 4. The tap water does not flash.
<ul style="list-style-type: none"> - Key (53) on - One button start (51) on - Press vacuum system adjustment button (54) on for 1 second - Seat safety switch (2) on - Accelerator pedal (32) pressed 		<ol style="list-style-type: none"> 1. Hour meter point flashes. 2. The brush arrow rotates. 3. The fan flashes. (Three blades) 4. The tap water flashes.
Off mode		
<ul style="list-style-type: none"> - Seat safety switch (2) off - One button start (51) off - Key (53) on 		<ol style="list-style-type: none"> 1. Hour meter point does not flash. 2. All panel button closure. (The vacuum motor delays 12 seconds to stop.) 3. The brush head puts up to the highest position. 4. "STOP" sign will alternate with the screen.
<ul style="list-style-type: none"> - Key (53) off - Or emergency button (29) on, there will no display 		<ol style="list-style-type: none"> 1. The power cut off. 2. The display is off. <p>Note: After turning off the one button start (51), wait until the brush head raises to the full up position, before turning off the key (53).</p>

HOW TO OPERATE	DISPLAY	DESCRIPTION
ECO mode		
<ul style="list-style-type: none"> - Key (53) on - One button start (51) on - ECO button (55) on 		<ol style="list-style-type: none"> 1. Water flow at minimum (level 1). 2. Pressure at minimum (level 1). 3. The vacuum in silent mode. <p>Note: Turn on one button start (51), before turning on ECO button (55).</p>
Vacuum system mode (press the button 1 second to activate)		
Normal mode		
<ul style="list-style-type: none"> - Seat safety switch (2) on - Key (53) on - One button start (51) off - Press vacuum system adjustment button (54) 		The fan flashes (four blades)
Silent mode		
<ul style="list-style-type: none"> - Seat safety switch (2) on - Key (53) on - One button start (51) off - Press vacuum system adjustment button (54) for 1 second 		The fan flashes (three blades)
<ul style="list-style-type: none"> - Seat safety switch (2) on - Vacuum system adjustment button (50) Off 		NO fan Note: When the vacuum system adjustment button is off, the vacuum motor immediately stops.
Reverse mode		
<ul style="list-style-type: none"> - Seat safety switch (2) on - Forward-reverse button (52) on 		<ol style="list-style-type: none"> 1. Hour meter point flashes. 2. Squeegee will up if it is in work mode.
Mechanical brake mode		
<ul style="list-style-type: none"> - Seat safety switch (2) on - Depress mechanical brake pedal (25) 		Machine stop. Others function keep.

TECHNICAL PARAMETERS

Parameter Type	AS1050R
Voltage	36 V
Rated power	125A/4500W
IP protection class	IP24
Solution tank capacity	200L / 53 Gal.
Recovery tank capacity	200L / 53 Gal.
Scrubbing width	980mm / 35.58 Inches
Brush/Pad diameter	508 mm x 2 /20 Inches x 2
Brush/Pad pressure (max)	90 Kg /198 Lbs.
Brush motor power	2 X 1000 Watt / 2 X 1.3 HP
Brush speed in normal mode	240 RPM
Brush speed in ECO mode	175 RPM
Solution Flow (max) per setting/minute	(1.6/2.3/3.3/4.6) Liters / 0.42/0.61/0.87/1.22Gal
Sound pressure level (one vacuum motor)	72 ± 3 dB (A)
Sound pressure level (two vacuum motors) (*)	75 ± 3 dB (A)
Sound pressure level in ECO mode or in silent mode	69 ± 3 dB (A)
Vacuum motor power	600 W / 0.8 HP
USB charging	5V 2.4A MAX.
Productivity (max)	7840 m ² /h/84389 ft ² /h
Working speed	0 – 8.0 Km / 0 - 5.0 Miles per hour
Forward speed	0 – 8.0 Km / 0 - 5.0 Miles per hour
Reverse speed	0 – 5 Km / 0 - 3.1 Miles per hour
Drive motor power	1600 W / 2.1 HP
Min. aisle turn	2650mm/104 Inches
Climbing capacity (max) transport	20%
Climbing capacity (max) working	16%
Drive wheel diameter	340mm / 13.4 Inches
Drive wheel specific pressure on the floor	0.68 N/mm ²
Front wheel diameter	250 mm / 10 Inches
Front wheel specific pressure on the floor	0.62 N/mm ²
Handle Vibration Level (max)	< 2.5 m/s ²
Battery Compartment Size without tray (L x W x H)	(680x560x450) mm / 26.7 x 22 x 17.7 Inches
Battery Compartment Size with tray (L x W x H) (*)	(665x550x430) mm / 26.1 x 21.6 x 16.9 Inches
Machine Length without front bumper	1875mm/73.8 Inches
Machine width without squeegee	1077mm/42.4 Inches
Machine Height	1350 mm / 53 Inches
Machine Height (with overhead guard)	1955mm / 77 Inches
Machine weight with empty tanks (without batteries)	398 Kg / 853.6 Lbs.
Gross Vehicle Weight (GVW)	870 Kg / 1914 Lbs.
Gross Vehicle Weight (GVW) (with overhead guard)	897 Kg / 1973 Lbs.
Shipping Weight	490 Kg / 1078 Lbs.
Packing dimensions (L x W x H)	(2110 x 1220 x 1535 mm) / (83x 48 x 60.4 Inches)

(*) : Optional

WIRING DIAGRAM

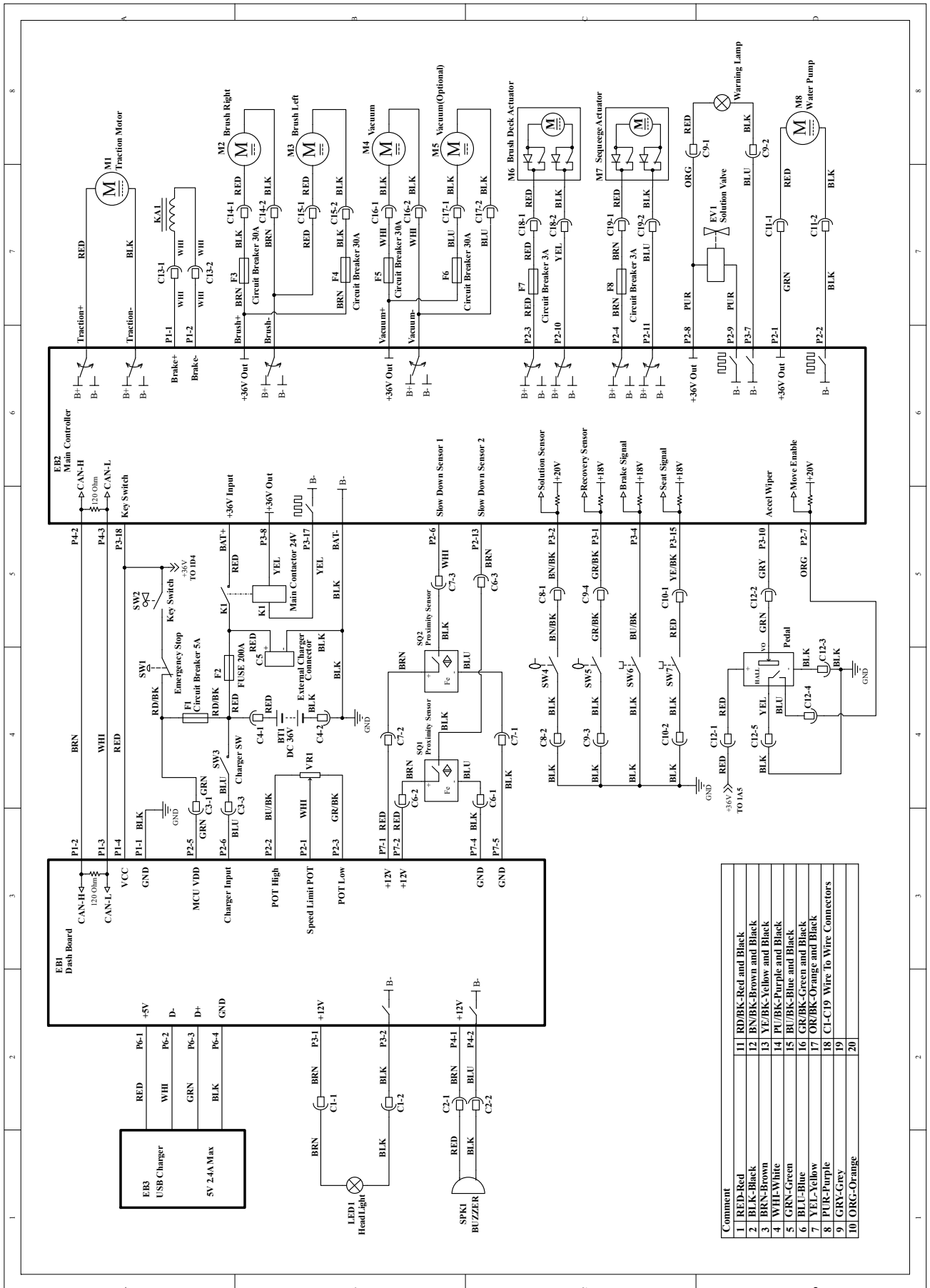

OPERATING GUIDE

**WARNING!**

On some points of the machine there are some adhesive plates indicating:

- DANGER!
- WARNING!
- CAUTION!
- CONSULTATION

While reading this Manual, the operator must pay attention to the symbols shown on the plates. Do not cover these plates for any reason and immediately replace them if damaged.

BATTERY CHECK/SETTING ON A NEW MACHINE

**WARNING!**

The electric components of the machine can be seriously damaged if the batteries are either improperly installed or connected. The batteries must be installed by qualified personnel only. Set the battery type using the procedure below according to the type of batteries used (WET or GEL/AGM/DIS/ENE batteries). Check the batteries for damage before installation. Disconnect the battery connector and the battery charger plug. Handle the batteries with great care. Install the battery terminal protection caps supplied with the machine.

**NOTE**

The machine requires six 6V batteries, connected and installed in the positions shown in Figure 5.

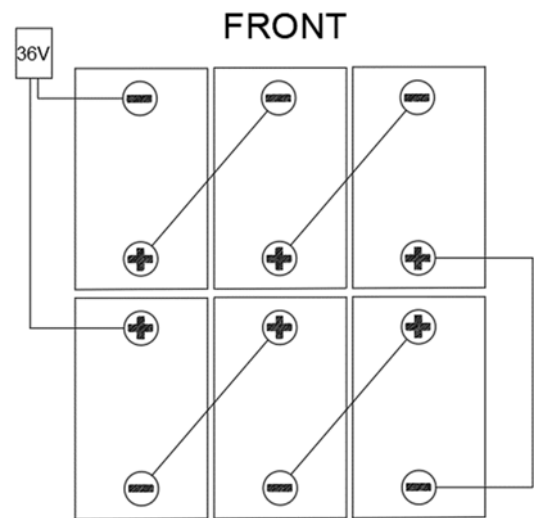

Figure 5

Batteries already installed on the machine

1. Ensure that the battery connector is connected.
2. When first using the machine with new batteries, perform a full charging cycle (see the procedure in Maintenance chapter).

Without batteries

1. Buy appropriate batteries (see “Technical Data” paragraph). For battery choice and installation, contact qualified battery Retailers.
2. Set the battery type setting using the procedure below.

BATTERY INSTALLATION AND BATTERY TYPE SETTING (WET /GEL/ AGM/ DIS/ENE)
Battery installation

1. Open the left and right latches (7 Figure1).
2. Open the recovery tank lid (5 Figure1) and check that the recovery tank (8 Figure1) is empty; otherwise empty it with the drain hose (38 Figure2).
3. Close the recovery tank lid (5 Figure1).
4. Raise the recovery tank (8 Figure1) carefully.
5. Disconnect the recovery tank cable and remove the whole recovery tank assembly.
6. Remove one screw of the recovery tank turning cable (31 Figure2) and turn the tank back.
7. Remove recovery tank four screws on the bottom of it.

The machine is supplied with cables suitable to install six 6V batteries. Carefully put the batteries into the compartment, then install them correctly as shown in Figure 5. Put the battery fixed plate correctly.

8. Route and install the battery cable as shown in Figure 5, then carefully tighten the nut on each battery terminal.

9. Place the protective cap on each terminal, then connect the battery connector to machine.
10. Assemble the whole recovery tank assembly in the reverse order of disassembly.
11. Carefully lower the recovery tank.

Battery type setting (WET/GEL/AGM/DIS/ENE)

Access to select battery mode

According to the type of batteries (WET/GEL/AGM/DIS/ENE), set the machine as follows:

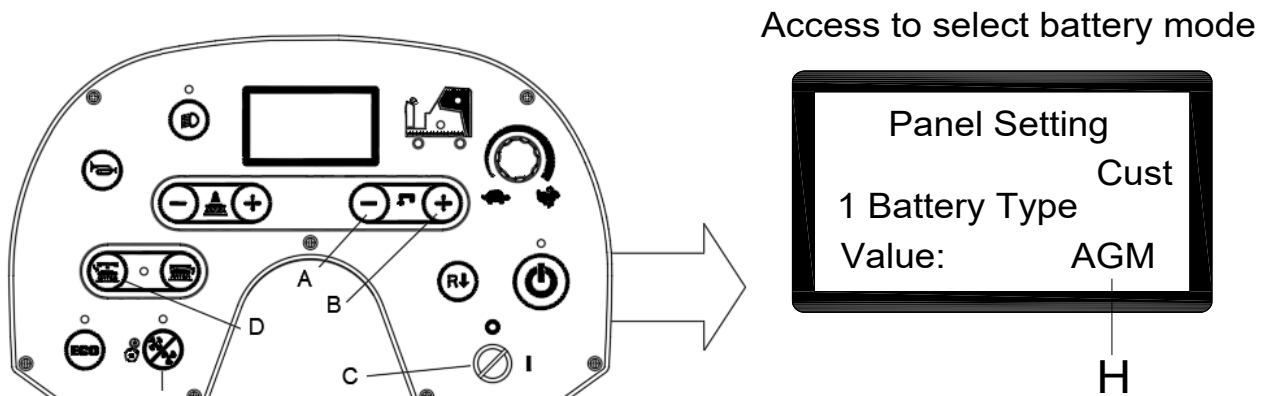

Figure 6

1. Press water flow button "-"(A, Figure 6) and "+"(B, Figure 6) at the same time.
2. Insert the ignition key (C, Figure 6) and turn it to "I".
3. Several seconds later enter to the screen of selecting battery mode (Figure 6).
4. Press water flow button "-"(A, Figure 6) and "+"(B, Figure 6) to select battery mode (H, Figure 6).
5. Press the release button (D, Figure 6), 3 seconds later show " Update OK" means setting succeeds, restart machine. (C, Figure 6).

Battery charging

Fully charge the batteries (see the procedure in Maintenance chapter).

Battery discharge

When the batteries pattern is full (G, Figure 7), the batteries are fully charged. When the batteries pattern is low (H, Figure 7), the batteries must be charged. A few seconds after the low battery pattern shows, the brush motors are automatically turned off, while the drive system stays on. Drive the machine to the appointed recharging area immediately.

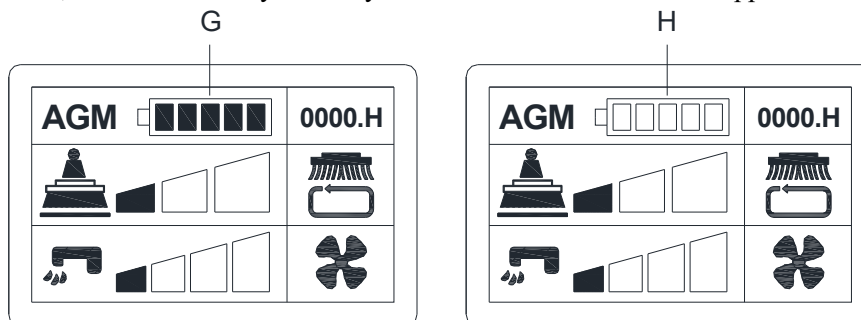

Figure 7

BRUSH/PAD-HOLDER INSTALLATION AND REMOVAL



NOTE

Install either the brush (A, Figure 8) or pad-holder (B and C, Figure 8) according to the type of floor to be cleaned.



CAUTION!

Before installation or removal of brush or pad-holder, make sure all the switches on machine are in off position and the squeegee is lifted off the floor. The operator must be equipped with suitable personnel protection devices, such as gloves to reduce the risk of accidents.

Proceed as following:**INSTALLATION:**

1. Insert the Ignition key (53, Figure 3) and turn it to "I". Lift the deck.
2. Place brushes (A, Figure 8) or pad-holders (B, Figure 8) under the deck. Use the brush installation stop (D, Figure 8) to help find the proper brush/pad holder position.
3. Install the brush/pad-holder by pressing the Brush/pad-holder click on button (F, Figure 8), the brush/pad-holder will be automatically installed. The rotation direction is shown (Figure 8). The LED indicator light will flash.

REMOVAL:

1. Insert the Ignition key (53, Figure 3) and turn it to "I". Insure the brush/pad-holder is in the raised (UP) position. Remove the brush/pad-holder by pressing the brush/pad-holder release button (E, Figure 8), the brush/pad-holder will be automatically released. The LED indicator light will be steady on.

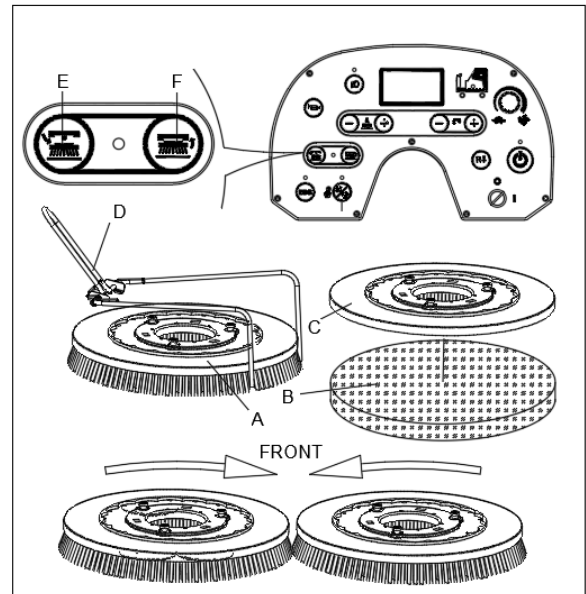
**Figure 8**

If press brush click-off button and press click-on button, you must turn off ignition key then turn on it, machine can work again.

ADJUSTING THE BALANCE OF SIDE SPLASHGUARDS

The splashguard height needs to be monitored, and adjusted. While cleaning with the machine, check the performance of the side splashguards.

- A. If the splashguards are too high, the gap between the splashguard (D) and the floor, will leave water on the floor during turns.
- B. If the splashguards are too low, the splashguard (D) will deflect too far, leaving water during turns, and reducing the life of the splashguard.
- C. Proper adjustment is when the splashguards lightly touch the floor from the front to the rear of the splashguard.

Adjusting procedure as follows:

1. Insure the deck is in the raised (UP) position.
2. Loosen the top retention nuts (A), and remove the splashguard assembly.
3. Adjust the lower retention nuts (B) up/down.
4. Re-install the splashguard assembly and check the adjustment.
5. Repeat 3. & 4. as required until the splashguard adjustment is correct.
6. Tighten the tope retention nuts (A) to secure the adjustment.
7. Repeat the procedure on the other side splashguard.

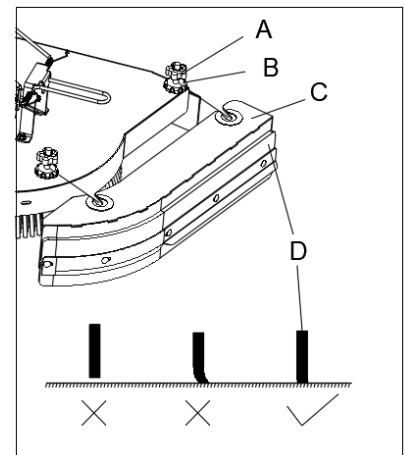
**Figure 9****ADJUSTING THE BALANCE OF SQUEEGEE**

1. Install the squeegee and tighten up the nuts (C, Figure 10), then connect the vacuum hose (B) to the squeegee.
2. Adjust the squeegee by squeegee adjusting knob (A).
 - a) If there is a gap between the ground and middle section of rear squeegee blade (E), adjust the knob (A) in clockwise direction (H) until all sections of the rear squeegee blade make good contact with the ground, and the front blade touches the ground slightly.
 - b) If there is a gap between the ground and both end sections of the rear blade (D and F), adjust the knob (A) in counterclockwise direction (G) until all sections of the rear squeegee blade make good contact with the ground, and the front blade touches the ground slightly.

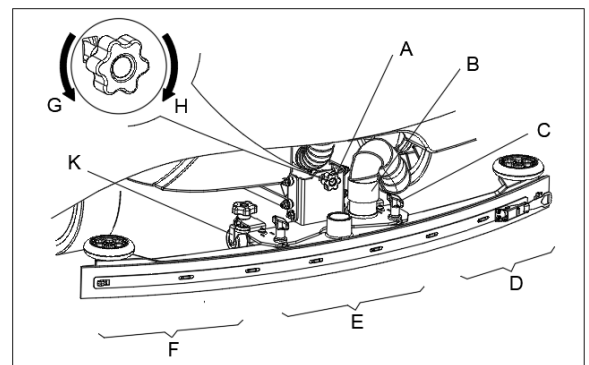
**Figure 10**

If nesseray, adjust the whole squeegee height by adjust the caster wheel (K) height.

FILLING SOLUTION TANK

1. Open the water inlet cover (A, Figure 11).
2. Fill with water or solution suitable for work performance through the water inlet with filter.
The solution temperature must not exceed +104F (+40°C).
3. Do not overfill the tank, refer to water level indicator (D) for the water volume.



WARNING!

Use only low-foam and non-flammable detergents, intended for automatic scrubber applications.

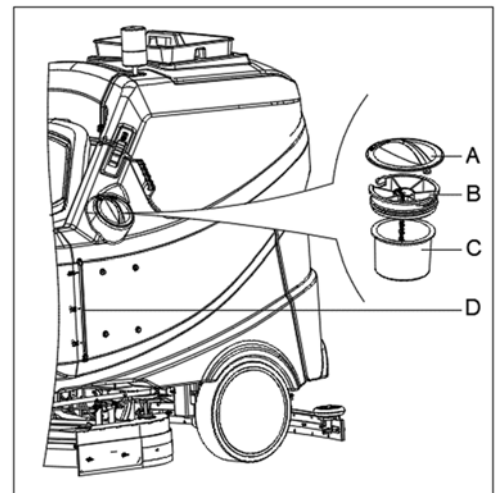

Figure 11

DRIVE MOTOR AND MECHANICAL BRAKE INSPECTION

1. Turn the ignition key (A Figure 12) to “I”, sit on the seat (C).
2. Depress the accelerate pedal (D) slightly then release it to check if the machine can be steered forward and stopped.
3. To ensure safety, confirm the machine can be stopped immediately when pressing the emergency button (B). Rotate the emergency button to reset it.
4. Depress the mechanical brake pedal (F) quickly to check if the machine can be stopped immediately.

WARNING!

Working climbing capacity shall not exceed 16%. When working on slope, must keep the tank latches (7 Figure 1) engaged. For safety, never stop it on slope.

When climbing a slope with maximum 20% inclination, adjust the speed limiting potentiometer to the maximum speed position in advance. Push the accelerator pedal to the maximum while climbing the slope.

If scrubbing in a slope with maximum 16% inclination, adjust the speed limiting potentiometer to the maximum speed position in advance. If the display reads “Error 4, Tra Overload”, adjust brush pressure to the lowest setting.

If you find that the machine speed is getting slower and close to the stop state in the process of climbing a slope and “Error 4, Tra Overload” is showing on the display. Release the accelerator pedal immediately and step on the mechanical brake.

If “Error 4, Tra Overload” is displayed in the process of climbing a slope. Immediately stop and step on the mechanical brake, turn the key switch to off, and then turn on the key to restart and give up the climbing operation. Adjust the speed limit potentiometer to a slow speed position, and then press the backward button, release the mechanical brake, gently step on the accelerator so that the machine can move backward slowly until a lower inclination have been reached.

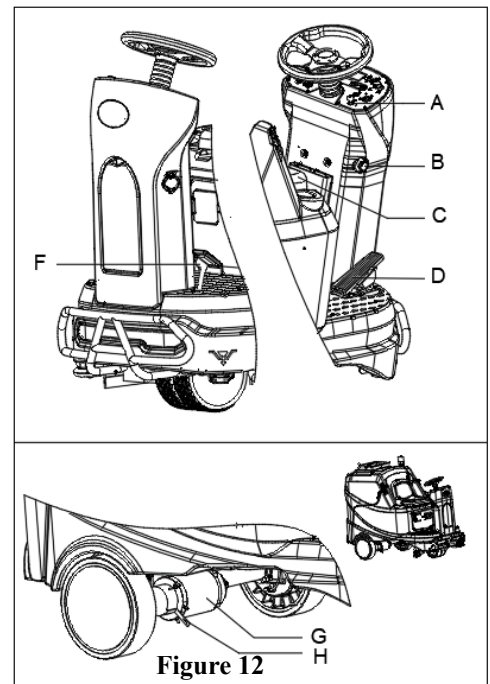

Figure 12



CAUTION

The brake of drive motor is released when the motor works normally, it locks when the motor is off. In some special cases, such as machine packing/unpacking, machine fault etc., the machine may need to be pushed. On drive motor (G Figure 12) push down the brake handle (H Figure 12), the machine brake is released, and the machine can be moved. After completion, push up the handle back, so the machine can work

MACHINE START AND STOP

Start the machine

1. Prepare the machine as shown in the previous paragraph.

2. Sit on the seat (K Figure13), insert the Ignition key (J Figure13) and turn it to “I”. Check batteries status from display screen. If necessary to charge the batteries (see the procedure in Maintenance chapter).
3. Drive the machine to the working area.

The forward/reverse direction can be controlled with the switch (H Figure13). The speed can be adjusted with the adjuster (E Figure13).

4. Press One-Start button (G, Figure13) to start the machine, the squeegee and brushes are lowered to the floor automatically, and the vacuum motor begins to work.
5. Press the solution flow control buttons (F, Figure13) as necessary, depending on the type of cleaning to be performed.
6. Depress the accelerator pedal (Q Figure13), and start cleaning.
7. You can charge your phone or pad through USB charging port (M Figure13) when the Ignition key (J Figure13) is turned to “I”.
8. Press the horn button (B Figure13) to warn people when necessary.
9. If necessary, press the emergency button (N Figure13) for machine emergency stop.
10. If necessary, press the front lights button (C Figure13) for dark areas or to warn pedestrians.
11. If necessary, adjust the seat (K Figure13) by turning right the handle on the right of seat, then slide the seat to proper position.



NOTE

The brush motor, vacuum motor, drive motor and control circuit are protected by overload protector (P Figure13). When an overload protector trips, do not reset it immediately without finding out the root cause, and make sure the motor has cooled before reset.

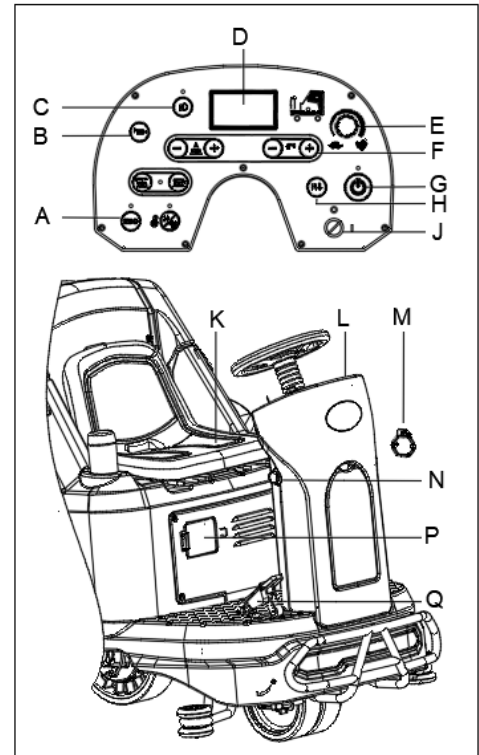

Figure 13

Stop the machine

12. Release the accelerator pedal (Q Figure13), the machine stops running.
13. Press One-Start button (G Figure13) to stop brushes and vacuum motor. The brushes and squeegee are lifted from the floor automatically. The vacuum system will turn off after a few seconds.
14. Turn the Ignition key to “0”.
15. Make sure the machine cannot move independently.

MACHINE OPERATION (SCRUBBING AND DRY-ING)

1. Start the machine according to procedures in previous paragraphs.
2. Start cleaning by following procedures in section of “Starting the machine”.
3. If necessary, stop the machine to adjust side splashguards according to section “Adjusting the balance of side splashguards”.
4. If necessary, stop the machine to adjust squeegee according to section “Adjusting the balance of squeegee”.



NOTE

For correct scrubbing/drying of floors at the sides of the walls. It is suggested to go near the walls with the right side of the machine (Figure 14) as shown in the figure.

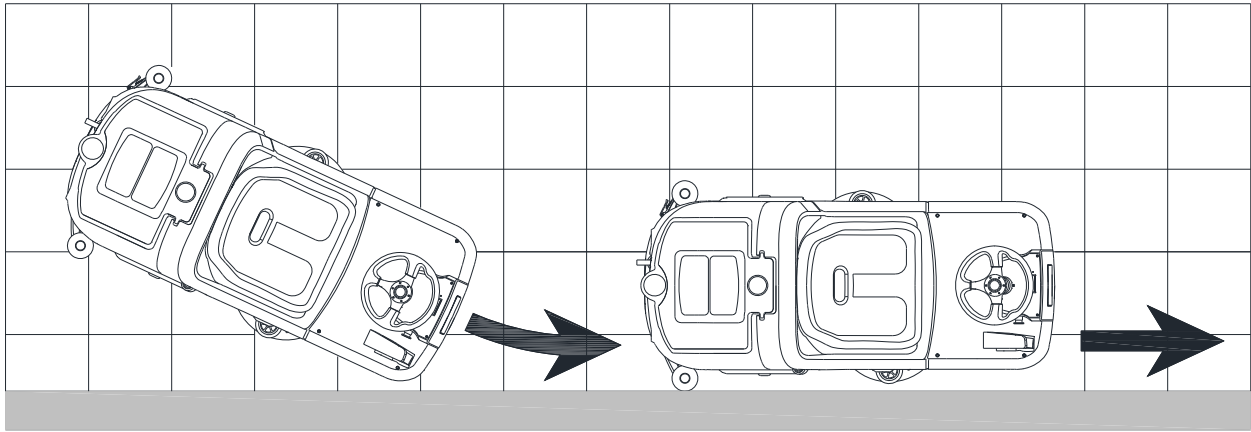

Figure 14

TANK EMPTYING

Recovery water tank emptying

When the Multifunction display (47, Figure 3) show ERROR24 and the recovery tank full indicator (48, Figure3) is turned on. It indicates the recovery tank (C, Figure15) is full, the vacuum motor cannot longer dry the floor. Empty the recovery tank as following steps:

1. Stop the machine.
2. Lift the brush/pad-holder deck and the squeegee by pressing the one-button start (51, Figure 3).
3. Drive the machine to the appointed disposal area.
4. Empty the recovery water tank with the hose (D, Figure 15). Then, rinse the tank (C, Figure 15) with clean water.

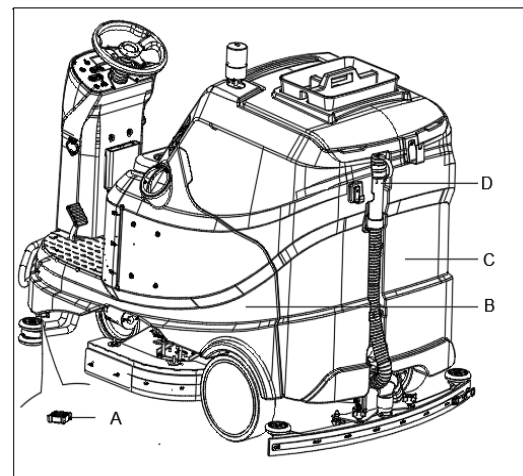

Figure 15



CAUTION!

When draining the wastewater, the hold the drain hose high, and fold over the top section to avoid spilling onto the operator.

Solution/clean water tank emptying

1. Empty the solution tank with the outlet cover (A, Figure 15). After working, rinse the tank with clean water.

AFTER USING THE MACHINE

After working, before leaving the machine:

1. Remove the brushes/pad-holders by pressing the release left button (56, Figure 3) and clean them.
2. Empty the tanks (B and C, Figure 15) as shown in the previous paragraph.
3. Perform the daily maintenance procedures (see the Maintenance chapter).
4. Store the machine in a clean and dry place, with the brushes/ pad-holders and the squeegee lifted or removed.
5. Use the recovery tank lid support to keep the lid open. This will help prevent odors from building up inside.

MACHINE STORAGE DURING LONG INACTIVITY

If the machine is not going to be used for more than 30 days, proceed as follows:

1. Perform the procedures shown in After Using the machine paragraph.
2. Disconnect the battery connector.

FIRST PERIOD OF USE

After the first 8 hours, check the machine fastening and connecting parts for proper tightening and check the visible parts for wear and leakage.

MAINTENANCE**WARNING!**

Maintenance procedures must be performed after the machine is turned off and the battery charger cable is disconnected. In addition, carefully read the safety chapters in these instructions.

All scheduled or extraordinary maintenance procedures must be performed by qualified personnel or an authorized Service Center. This manual only describes the general and common maintenance procedures.

For other maintenance procedures that are not in below maintenance schedule table, please contact our Technical Support Department.

SCHEDULED MAINTENANCE TABLE**CAUTION!**

The procedure marked with (1) must be performed when the machine is used after 8 hours for the first time. The procedure marked with (2) must be done by Service Center that qualified by our company.

Procedure	Daily, after each use	Weekly	Semiannually	Yearly
Battery charging				
Squeegee cleaning				
Brush/Pad-holder cleaning				
Tank cleaning				
Tank gasket strip inspection				
Debris collection box cleaning				
Brush/Pad cleaning				
Splash guard cleaning				
Squeegee blade check and replacement				
Solution filter cleaning				
Vacuum intake filter cleaning				
WET battery fluid level check				
Screw and nut tightness inspection			(1)	
Add lubricating oil for rotating parts (like brake oil)			(1)	
Brush motor carbon brush check or replacement				(2)
Vacuum motor carbon brush check or replacement				(2)
Drive system motor carbon brush check or replacement				(2)

BATTERY CHARGING**NOTE**

Charge the batteries when the battery is low.

**CAUTION!**

Keeping the batteries charged make their life last longer.

**CAUTION!**

When the batteries are discharged, charge them as soon as possible, as that condition makes their life shorter. Check for battery charge at least once a week.

**WARNING!**

WET battery charging produces highly explosive hydrogen gas. Charge the batteries in well-ventilated areas and away from naked flames. Do not smoke while charging the batteries. Keep the tank open while charging the batteries.

**WARNING!**

Pay careful attention when charging the batteries as there may be battery fluid leakages. The battery fluid is corrosive. If it contacts with skin or comes into eyes, rinse thoroughly with water and consult a physician.

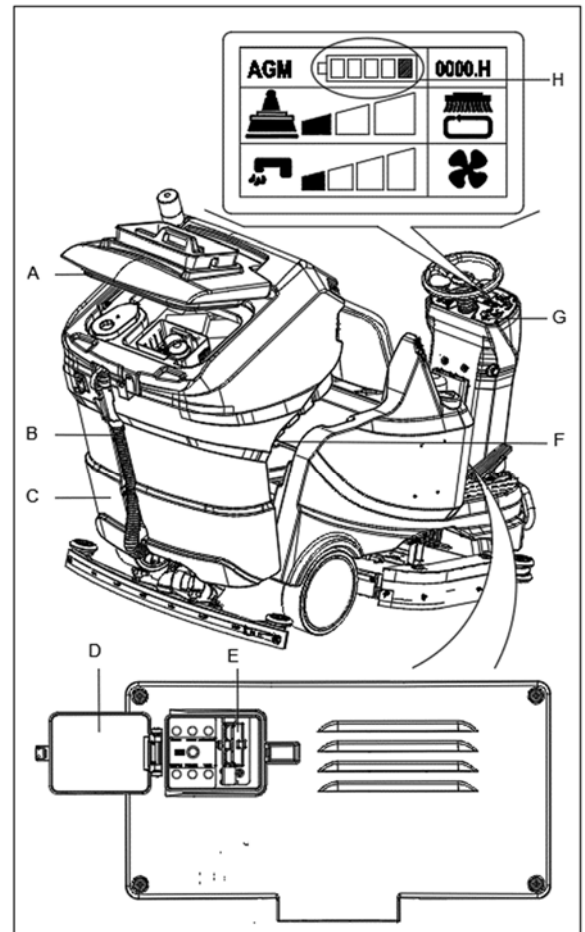
**Figure 16****Preliminary procedures**

1. Open the cover (A, Figure 16) and check that the recovery water tank (C, Figure 16) is empty, otherwise empty it with the drain hose (B, Figure 16).
2. Drive the machine to designated charging area.
3. Turn the Ignition key (G, Figure 16) to "0".
4. Charge the batteries according to the following procedure.

Battery charging (The machine with off-board charger)

5. Open the protective cover (D, Figure 16). Connect the battery charger connector to the connector on the machine (E, Figure 16). When the battery charger is connected, all machine functions are automatically cut off.
6. Plug the battery charger into the wall socket.
7. When the battery charging is completed, unplug the charger from the wall socket, then disconnect the battery charger cable from machine.
8. Electrolyte levels should be checked after the batteries are charged.
9. Insert the Ignition key (G, Figure 16) and turn it to "I". Check the status of batteries on multifunction display screen (H, Figure 16).

BRUSH/PAD CLEANING**CAUTION!**

It is advisable to use protective gloves when cleaning the brush/pad because there may be sharp debris.

1. Remove the brush/pad from the machine, as shown in the Use chapter.
2. Clean and wash the brush/pad with water and detergent.
3. Check that the brushes/pads are in working condition and not excessively worn; if necessary replace them.

SOLUTION FILTER CLEANING

1. Drive the machine a level section of floor.
2. Ensure that the machine is off and the Ignition key (53, Figure 3) has been removed.
3. Empty the solution tank or turn off the tap (24, Figure 1).
4. Remove the filter cover (22, Figure 1), then remove the filter strainer. Clean the strainer, and re-install it onto the filter base.
5. Check the filter "O" ring gasket. If there is damage, replace it.
6. Re-install the filter cover.



NOTE

The filter strainer must be correctly positioned on the housing of the filter base.

SQUEEGEE CLEANING



NOTE

The squeegee blades must be clean, and in good conditions for getting good drying action.



CAUTION!

It is advisable to wear protective gloves when cleaning the squeegee because there may be sharp debris.

1. Drive the machine to a level section of floor.
2. Turn the Ignition key (53 Figure 3) to "0".
3. Loosen the two knobs (B Figure 17) and remove the squeegee (A).
4. Disconnect the vacuum hose (C) from the squeegee.
5. Clean the steel or aluminum squeegee housing (F Figure 17). Clean the compartments (A) and the hole (G) especially. Check the front blade (D) and the rear blade (E) for integrity, cuts and tears; if necessary replace them (see the procedure in the following paragraph).
6. Assemble the squeegee in the reverse order of disassembly.

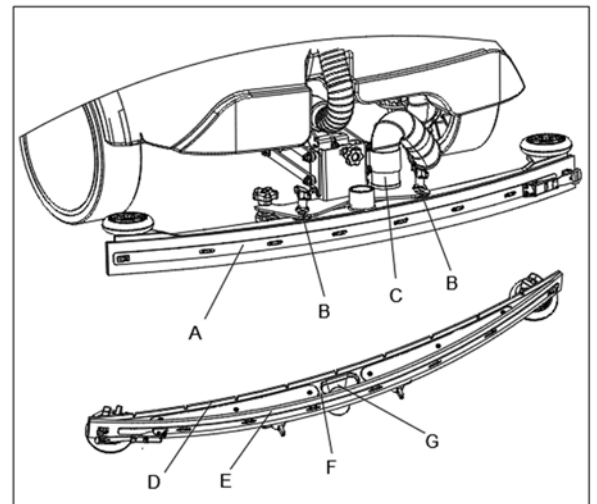

Figure 17

SQUEEGEE BLADE CHECK AND REPLACEMENT

1. Clean the steel or aluminum squeegee, as shown in the previous paragraph.
2. Check that the edges (E, Figure 18) of the front blade (C) and the edges (F) of the rear blade (D) lay down on the same level, along their length; if necessary, adjust their height according to the following procedure:
 - Remove the tie rod (G), disengage the fasteners (M) and adjust the rear blade (D), then engage the fasteners (M) and install the tie rod (G).
 - Loosen the knobs (I) and adjust the front blade (C), then tighten the knobs.
3. Check the front blade (C) and rear blade (D) for wear, cuts and tears; if necessary, replace them according to the following procedure. Check that the front edge (J) of the rear blade (D) is not worn; if necessary, turn the blade over to replace the worn edge with an integral one. If the other edges are worn too, replace the blade according to the following procedure:

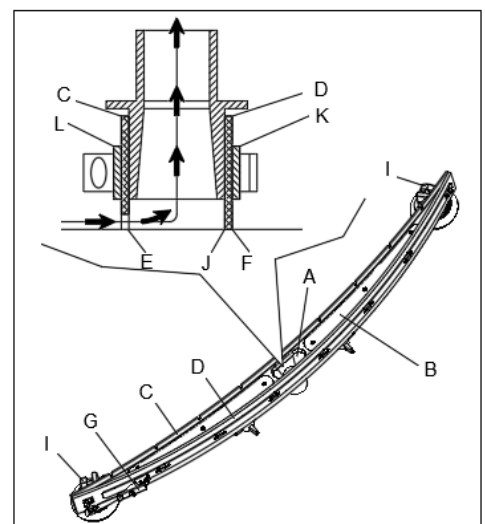

Figure 18

- Remove the tie rod (G), disengage the fasteners (M) and remove the retaining strip (K), then replace the rear blade (D). Assemble the blade in the reverse order of disassembly.
 - Unscrew the knobs (I) and remove the retaining strip (L), then replace the front blade (C). Assemble the blade in the reverse order of disassembly. After the blade replacement (or turning over), adjust the height as shown in the previous step.
4. Connect the vacuum hose (A, Figure 18) to the squeegee.
 5. Install the squeegee (B) and screw down the knobs (C).
 6. If necessary, adjust the squeegee balance adjusting knob (35 Figure2).

TANK AND DEBRIS COLLECTION BOX CLEANING, AND COVER GASKET CHECK

1. Drive the machine on a level floor.
2. Ensure that the machine is off and the key witch (53, Figure 3) has been removed.
3. Open the recovery tank lid (A, Figure 19) and make sure the support (B) is working.
4. Clean the recovery tank lid (A), recovery tank (F), the vacuum filter (C) and the debris collection box (D). Empty the recovery tank with the drain hose (E).
5. Inspect the integrity of the tank gasket strip.



CAUTION!

Insure the lid support is latched properly. Take care that the tank lid is not open too far and you do not bump into the support, while working inside. The tank lid can close suddenly.



NOTE

Tank gasket strip (G) is critical to produce the suction inside the tank when the vacuum motor is working. The tank must be sealed so it can effectively move the water from the ground to the recovery tank.

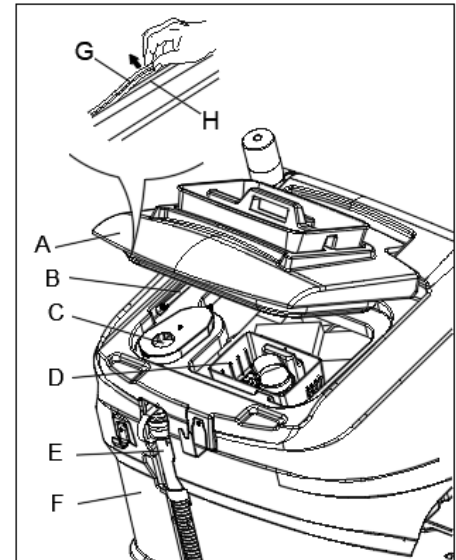

Figure 19

6. Check whether the contact surface of gasket strip (G) is good condition and sealing is sufficient. If necessary, take the gasket strip of the tank out of the groove (H) and replace it. Assemble the new gasket strip as shown in (Figure 19), the joint should be back in the middle area.
7. Close the recovery tank lid (A).

ACCESSORIES/OPTIONS

In addition to the standard components, the machine can be equipped with the following accessories/options, according to the machine specific use:

For further information concerning the above-mentioned optional accessories, contact an authorized Retailer.

ACCESSORIES/OPTIONS

See "Parts List" section

1. Brush of different materials
2. Mop clamp
3. Utility caddy
4. Overhead guard
5. Dual vacuum system

TROUBLESHOOTING

Trouble	Probable causes	Remedy
The motors do not work, error code on display	The battery connector is disconnected.	Connect the battery connector.
	The batteries are completely discharged.	Charge the batteries.
	Error code see the table.	Restart the machine.
The machine does not move	The machine is turn off with the Ignition key.	Turn on the Ignition key.
	Emergency button is pressed.	Release the emergency button.
	The operator is not on the seat.	Sit on the seat.
The recovery water vacuuming is insufficient.	The recovery water tank is full.	Empty the tank.
	The hose is disconnected from the squeegee.	Connect.
	The debris collection box is full, or the squeegee hose outlet is clogged.	Clean the box or the outlet.
	The squeegee is dirty or the squeegee blades are worn or damaged.	Clean and check the squeegee.
	The tank lid is not properly closed, or the gasket is damaged, or the standpipe tube is clogged.	Close the lid correctly, or replace the gasket or clean the Bend tube.
	The vacuum hose is clogged.	Clean.
The solution flow to the brushes is insufficient.	The solution/clean water filter is dirty.	Clean the filter.
	Pump or valve was broken.	Replace the broken.
The squeegee leaves marks on the floor.	There are debris under the squeegee blades.	Remove the debris.
	The squeegee blades are worn, chipped or torn.	Replace the blades.
	The squeegee has not been adjusted with the knob.	Adjust.
	The side splashguards are not adjusted well.	Adjust.

ERROR CODE OF DISPLAY

Error 1	Valve Overload	Valve short circuit or overload
Error 2	Brush Overload	Brush motor short circuit or overload
Error 3	Vacuum Overload	Vacuum motor short circuit or overload
Error 4	Tra Overload	Traction motor short circuit or overload
Error 5	Bru-D Overload	Brush actuator motor short circuit or overload
Error 6	Battery Low	Low battery voltage
Error 7	Brush Open	Brush motor wiring is open circuit
Error 8	Vacuum Open	Vacuum motor wiring is open circuit
Error 9	Valve Open	Water valve wiring is open circuit
Error 10	Switch SRO	When key switch is on, accelerator is pressed.
Error 11	Tract Carbon	Remind user to change traction motor carbon
Error 12	Brush Carbon	Remind user to change brush motor carbon
Error 13	Vacuum Carbon	Remind user to change vacuum motor carbon
Error 14	C EEPROM Err	EEPROM error or parameter setting error
Error 15	P EEPROM Err	EEPROM error or parameter setting error
Error 16	Comm Err	Communication wiring broken
Error 17	C Self-Test Err	1.Accelerator fault 2. Internal relay welded 3.Mosfet or other hardware fault
Error 18	Overheat	1.Controller overheat 2.Mosfet overheat
Error 19	Battery High	Battery voltage>44V
Error 23	Clean Empty	Clean water tank is empty or clean water switch wiring problem
Error 24	Dirty Full	Dirty water tank is full or dirty water switch wiring problem

Error 26	Brake Err	Brake short circuit or overload
Error 27	Water Pump Err	Water pump short circuit or overload
Error 28	SQU Overload	Squeegee actuator motor short circuit or overload
Error 29	Beeper Overload	Beeper short circuit or overload
Error 30	E-CONT Overload	External contactor short circuit or overload
Error 31	Speed Limit Err	Speed potentiometer is out of range(100+/-20K)
Error 32	A-Lamp Overload	Alarm lamp short circuit or overload
Error 33	Light Overload	Light short circuit or overload
Error 34	Machine Locked	Machine is locked
Error 35	IOT Missing	IOT module is missing
Error 36	Brake Open	Electromagnetic brake wiring open circuit
Error 39	USB Overload	USB Charger Overload

**NOTE**

When the screen displays an error code. Restart the machine by Ignition key (53, Figure 3). If the error can't be eliminated, please contact our company service center.

SCRAPPING

Scrap the machine by the qualified waste treatment institution.

Before the machine is scrapped, please take away and segregate below subassembly that relevant laws and regulations request must be disposed in appropriate way.

- Battery
- Brush/Pad-holder
- Plastic hose and plastic parts
- Electrical and electronic components (*)

(*) Please contact our company service center when destroying any electrical and electronic components.

Machine material composition and recyclability

Type	Recyclable percentage	Weight percentage
Aluminum	100%	1%
Electric motors-various	29%	20%
Ferrous materials	100%	39%
Wiring harness	80%	1%
Liquids	100%	0%
Plastic-non-recyclable material	0%	1%
Plastic-recyclable material	100%	35%
Rubber	20%	3%

Company information:
www.vipercleaning.eu
info-eu@vipercleaning.com

